



Dignity® Dual Power Injectable

Implantable Infusion Port

INSTRUCTIONS FOR USE

DESCRIPTION:

- The Dignity® Dual power injectable implantable infusion port is an implantable access device designed to provide repeated access to the vascular system. Port access is performed by percutaneous needle insertion using a non-coring needle. **Power injection is performed using a power injectable needle only.** The Dignity® Dual Port device consists of two primary components: an injection port with self sealing septa and a radiopaque catheter. The Dignity® Dual Ports can be identified subcutaneously by feeling the top of the septum and the top rim of the port housing. Power Injectable Implantable Infusion Ports can be identified by the letters "CT" under radiographic imaging.
- **All materials are biocompatible. This device is not made with natural rubber latex, and is safe with CECT and is MR Conditional.**

INDICATIONS FOR USE:

- The Dignity® Dual Port is a power injectable implantable infusion port that is indicated for patient therapies requiring repeated access to the vascular system. The Dignity® Dual Port can be used for infusion of medications, I.V. fluids, parenteral nutrition solutions, blood products, and for the withdrawal of blood samples.
- When used with a power injectable needle, the Dignity® Dual Port is indicated for power injection of contrast media. For power injection of contrast media, the maximum recommended infusion rate is 5 ml/s with a 19 or 20 gauge non-coring power injectable needle. The maximum recommended infusion rate is 2 ml/s with a 22 gauge non-coring power injectable needle.

CONTRAINDICATIONS, WARNINGS, AND PRECAUTIONS

CONTRAINDICATIONS:

- This device is contraindicated for catheter insertion in the subclavian vein medial to the border of the first rib, an area which is associated with higher rates of pinch-off.^{1,2}
- The device is also contraindicated:
 - When the presence of device related infection, bacteremia, or septicemia is known or suspected.
 - When the patient's body size is insufficient for the size of the implanted device.

- When the patient is known or is suspected to be allergic to materials contained in the device.
- If severe chronic obstructive lung disease exists.
- If the prospective insertion site has been previously irradiated.
- If the prospective placement site has previously suffered episodes of venous thrombosis or vascular surgical procedures.
- If local tissue factors will prevent proper device stabilization and/or access.

WARNINGS:

I. During Placement:

- Intended for **Single Patient Use. DO NOT RE-USE.** Medcomp® products are single use devices and should never be reimplanted. Any device that has been contaminated by blood should not be re-used or resterilized.
- After use, this product may be a potential biohazard. Handle and discard in accordance with accepted medical practice and applicable local, state and federal laws and regulations.
- During placement through a sheath, hold thumb over exposed opening of sheath to prevent air aspiration. The risk of air aspiration is reduced by performing this part of the procedure with the patient performing the Valsalva maneuver.
- Do not suture catheter to port. Any damage or constriction of catheter may compromise power injection performance.
- Avoid vessel perforation.
- Do not power inject through a port system that exhibits signs of clavicle-first rib compression or pinch-off as it may result in port system failure.
- Do not proceed if resistance is felt or interaction between components failing.

II. During Port Access:

- DO NOT USE A SYRINGE SMALLER THAN 10ml. Prolonged infusion pressure greater than 25 psi may cause damage to a patient's vessels or viscus.
- **Dignity® Dual power injectable implantable infusion ports are only power injectable when accessed with a power injectable needle.**
- Failure to warm contrast media to body temperature prior to power injection may result in port system failure.
- Failure to ensure patency of the catheter prior to power injection studies may result in port system failure.
- Power injector machine pressure limiting feature may not prevent over pressurization of an occluded catheter.
- Exceeding the maximum flow rate may result in port system failure and/or catheter tip displacement.
- Dignity® Dual power injectable implantable infusion port device indication for power injection of contrast media implies the port's ability to withstand the procedure, but does not imply appropriateness of the procedure for a particular patient nor for a particular infusion set. A suitably trained clinician is responsible for evaluating the health status of a patient as it pertains to a power injection procedure and for evaluating the suitability of any infusion set used to access the port.
- Do not exceed a 325 psi pressure limit setting, or the maximum flow rate setting on the power injection machine, if power injecting through the Dignity® Dual power injectable implantable infusion port device.
- Medical procedures on a patient's arm in which the system is implanted should be restricted as follows:
 - **Do not** withdraw blood from or infuse medication into any area of the arm where the system is located unless you are using the port.

- **Do not** measure the patient's blood pressure on this arm.

SIGNS OF PINCH-OFF:

Clinical:

- Difficulty with blood withdrawal
- Resistance to infusion of fluids
- Patient position changes required for infusion of fluids or blood withdrawal

Radiologic:

- *Grade 1 or 2 distortion on chest x-ray. Pinch-off should be evaluated for degree of severity prior to explantation. Patients indicating any degree of catheter distortion at the clavicle/first rib area should be followed diligently. There are grades of pinch-off that should be recognized with appropriate chest x-ray as follows:* ^{3,4}

Grade	Severity	Recommended Action
Grade 0	No distortion	No action
Grade 1	Distortion present without luminal narrowing	Chest x-ray should be taken every one to three months to monitor progression of pinch-off to grade 2 distortion. Shoulder positioning during chest x-rays should be noted as it can contribute to changes in distortion grades.
Grade 2	Distortion present with luminal narrowing	Removal of the catheter should be considered.
Grade 3	Catheter transection or fracture	Prompt removal of the catheter.

PRECAUTIONS:

- Carefully read and follow all instructions prior to use.
- Federal (U.S.A.) law restricts this device to sale by or on the order of a physician.
- Only qualified healthcare practitioners should insert, manipulate and remove these devices.
- Avoid inadvertent puncture of the skin or fascia with the tip of the tunneler.
- If the guidewire must be withdrawn while the needle is inserted, remove both the needle and wire as a unit to help prevent the needle from damaging or shearing the guidewire.
- Use only non-coring needles with the port.
- Prior to advancing the catheter lock, ensure that the catheter is properly positioned. A catheter not advanced to the proper region may not seat securely and lead to dislodgment and extravasation. The catheter must be straight with no sign of kinking. A slight pull on the catheter is sufficient to straighten it. Advancing the catheter lock over a kinked catheter may damage the catheter.
- Follow Universal Precautions when inserting and maintaining the catheter.

- Follow all contraindications, warnings, precautions and instructions for all infusates as specified by their manufacturers.
- Precautions are intended to help avoid catheter damage and/or patient injury.
- When utilizing the port for arm placement, the port should not be placed in the axillary cavity.
- Caution when using the devices. Be aware of sharps.
- Examine all devices after they are removed from the patient to ensure no foreign materials remain inside the patient.
- Examine port assembly and all components to ensure all connections are secure, and there are no leaks, damage, breaks or dislodgement before, during or after the procedure.

I. Prior to Placement:

- Examine package carefully before opening to confirm its integrity and that the expiration date has not passed. The device is supplied in a sterile package and is non-pyrogenic. Do not use if package is damaged, opened or the expiration date has passed. **STERILIZED BY ETHYLENE OXIDE**

STERILE	EO
----------------	-----------

- **Do not resterilize or re-use. Re-use may lead to infection or illness/injury.**



- Inspect kit for presence of all components.
- Check patient's records, and ask patient, whether they have any known allergies to chemicals or materials that will be used during the placement procedure.
- Fill (prime) the device with sterile heparinized saline or normal saline solution to help avoid air embolism. Remember that some patients may be hypersensitive to heparin or suffer from heparin induced thrombocytopenia (HIT) and these patients must not have their port primed with heparinized saline.
- When using an introducer kit, verify that the catheter fits easily through the introducer sheath.

II. During Placement:

- Do not allow accidental device contact with sharp instruments. Mechanical damage may occur. Use only smooth edged, atraumatic clamps or forceps.
- Take care not to perforate, tear, or fracture the catheter during placement. After assembling catheter to port, check assembly for leaks or damage.
- Do not use the catheter if there is any evidence of mechanical damage or leaking.
- Do not bend catheter at sharp angles during implantation. This can compromise catheter patency.
- Carefully follow the connection technique given in these instructions to ensure proper catheter connection and to avoid catheter damage.
- Do not use sutures to secure catheter to the port stem as it could collapse or damage the catheter.
- When using peel-apart introducers:
 - Carefully insert the introducer and catheter to avoid inadvertent penetration to vital structures in the thorax.
 - Avoid blood vessel damage by maintaining a catheter or dilator as internal support when using a peel-apart introducer.

- Avoid sheath damage by simultaneously advancing the sheath and dilator as a single unit using a rotational motion.

POSSIBLE COMPLICATIONS:

- The use of a subcutaneous port provides an important means of venous access for critically ill patients. However, the potential exists for serious complications, including the following:
 - Air Embolism
 - Bleeding
 - Brachial Plexus Injury Cardiac Arrhythmia Cardiac Tamponade
 - Catheter or Port Erosion Through the Skin
 - Catheter Embolism
 - Catheter Occlusion
 - Catheter Occlusion, Damage or Breakage Due to Compression Between the Clavicle and First Rib
 - Catheter or Port Related Sepsis
 - Device Rotation or Extrusion
 - Endocarditis
 - Extravasation
 - Fibrin Sheath Formation
 - Hematoma
 - Hemothorax
 - Hydrothorax
 - Intolerance Reaction to Implanted Device
 - Inflammation, Necrosis, or Scarring of Skin Over Implant Area
 - Laceration of Vessels or Viscus
 - Perforation of Vessels or Viscus
 - Pneumothorax
 - Spontaneous Catheter Tip Malposition or Retraction
 - Thoracic Duct Injury
 - Thromboembolism
 - Vascular Thrombosis
 - Vessel Erosion
 - Risks Normally Associated with Local or General Anesthesia, Surgery, and Post-Operative Recovery
- These and other complications are well documented in medical literature and should be carefully considered before placing the port.

IMPLANTATION INSTRUCTIONS:

- Please read through complete implantation instructions before implanting port, noting “Contraindications, Warnings, and Precautions” and “Possible Complications” sections of this manual before beginning procedure.

PREVENTING PINCH-OFF:

- The risk of pinch-off syndrome can be avoided by inserting the catheter via the internal jugular vein (IJ). Subclavian insertion of the catheter medial to the border of the first rib may cause catheter pinch-off, which in turn results in occlusion causing port system failure during power injection.

- If you choose to insert the catheter into the subclavian vein, it should be inserted lateral to the border of the first rib or at the junction with the axillary vein because such insertion will avoid compression of the catheter, which can cause damage and even severance of the catheter. The use of image guidance upon insertion is strongly recommended. A radiographic confirmation of catheter insertion should be made to ensure that the catheter is not being pinched.

IMPLANTATION PREPARATION:

1. Select implantation procedure to be used. **Note:** Recommended veins for arm placement are cephalic, basilic, or medial cubital basilic. **Note:** Recommended veins for chest placement are internal jugular or lateral subclavian. Refer to “Warning” section covering catheter pinch-off if inserting the catheter via subclavian vein.
2. Select the site for port placement. **Note:** Port pocket site selection should allow for port placement in an anatomic area that provides good port stability, does not interfere with patient mobility, does not create pressure points, has not previously been irradiated, does not show signs of infection, and does not interfere with clothing. For arm port placement, site should be distal to the desired vein insertion site. Consider the amount of cutaneous tissue over the port septum, as excessive tissue will make access difficult. Conversely, too thin a tissue layer over the port may lead to tissue erosion. A tissue thickness of 0.5cm to 2cm is appropriate.
3. Complete patient implant record, including product reorder number and lot number.
4. Perform adequate anesthesia.
5. Create sterile field and open tray.
6. Surgically prep and drape the implantation site.
7. For Attachable Catheters: Flush open-ended catheters with heparinized saline and clamp the catheter closed several centimeters from the proximal (port) end. Remember that some patients may be hypersensitive to heparin or suffer from heparin induced thrombocytopenia (HIT) and these patients must not have their port primed with heparinized saline. **Note:** Clamp catheter segments that will be cut off prior to attachment.

CUT-DOWN PROCEDURE:

1. Place patient in the Trendelenburg position with head turned away from the intended venipuncture site. For arm port placement, position the arm in an abducted, externally rotated position. Use a cut-down incision to expose the entry vein of choice.
2. Perform vessel incision after vessel is isolated and stabilized to prevent bleeding and air aspiration.

If using a vein pick, insert its tapered end through the incision and advance it into the vessel. Then slide the catheter tip into the grooved underside of the pick.

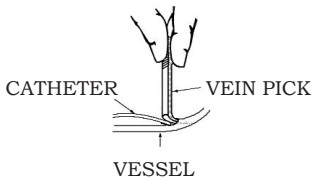

4. Advance the catheter tip into the vessel.
5. Withdraw the vein pick, if used.
6. Advance the catheter into the vessel to the desired infusion site. **Note:** Catheters should be positioned with the catheter tip at the junction of the superior vena cava and the right atrium. Verify correct catheter tip position, using fluoroscopy, or appropriate technology. Do not occlude or cut catheter when using sutures to secure catheter.

PERCUTANEOUS PROCEDURE:

1. Place patient in the Trendelenburg position with head turned away from the intended venipuncture site.
2. Locate desired vessel using a small gauge needle attached to a syringe. Refer to the “Warnings” section covering catheter Pinch-off, if inserting the catheter via the subclavian vein.

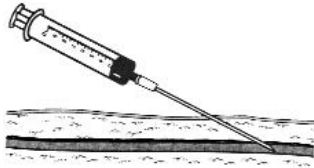

3. Attach introducer needle to the syringe and insert into vessel alongside the small gauge needle. Remove small gauge needle.
4. Aspirate gently as the insertion is made. If the artery is entered, withdraw the needle and apply manual pressure for several minutes. If the pleural space is entered, withdraw the needle and evaluate patient for possible pneumothorax.



5. When the vein has been entered, remove the syringe leaving the needle in place. Place a finger over the hub of the needle to minimize blood loss and the risk of air aspiration. The risk of air aspiration is reduced by performing this part of the procedure with the patient performing the Valsalva maneuver.



6. If using a micropuncture set, insert the flexible end of the guidewire into the needle. Advance the guidewire as far as appropriate. Verify correct positioning, using fluoroscopy or ultrasound. Gently withdraw and remove the needle, while holding the guidewire in position. **Caution:** If the guidewire must be withdrawn while the needle is inserted, remove both needle and wire as a unit to prevent the needle from damaging or shearing the guidewire. Advance the small sheath and dilator together as appropriate. Withdraw the dilator and guidewire, leaving the small sheath in place. **Warning:** Place a thumb over the orifice of the sheath to minimize blood loss and risk of air embolism.
7. Straighten "J" tip of guidewire with tip straightener and insert tapered end of tip straightener into the needle.



8. Remove the tip straightener and advance the guidewire into the superior vena cava. Advance the guidewire as far as appropriate for the procedure. Verify correct positioning, using fluoroscopy, or appropriate technology.

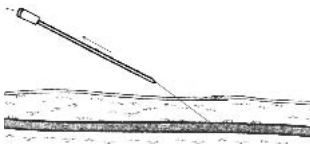

9. Gently withdraw and remove needle. **Caution:** If the guidewire must be withdrawn while the needle is inserted, remove both the needle and wire as a unit to help prevent the needle from damaging or shearing the guidewire.
10. If using a micropuncture set, gently withdraw and remove the small sheath, while holding the standard guidewire in position.

PEEL-APART SHEATH INTRODUCER INSTRUCTIONS:

1. Advance the vessel dilator and sheath introducer as a unit over the exposed wire using a rotational motion. Advance it into the vein as a unit, leaving at least 2cm of sheath exposed. **Note:** Placement may be facilitated by making a small incision to ease introduction of vessel dilator and sheath introducer. **Warning:** Avoid vessel perforation.

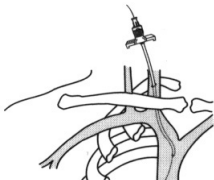

2. Release the locking mechanism and gently withdraw the vessel dilator and "J" wire, leaving the sheath in place.

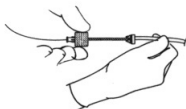

3. **Warning:** Hold thumb over exposed opening of sheath to prevent air aspiration. The risk of air aspiration is reduced by performing this part of the procedure with the patient performing the Valsalva maneuver.



4. Insert catheter into the sheath. Advance the catheter through the sheath into the vessel to the desired infusion site. Catheters should be positioned with the catheter tip at the junction of the superior vena cava and the right atrium.

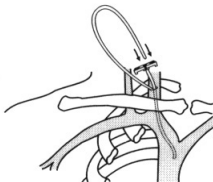

5. Verify correct catheter tip position using fluoroscopy, or appropriate technology. **Note: For arm-placed port,** move the patient's arm to several positions relative to the body. Using fluoroscopy, evaluate the effect of this movement on the catheter tip location during each movement. If appropriate, reposition the catheter so the tip is in the desired location. **Note:** Exercise care in the placement of the catheter tip. Movement of the patient's arm in which the system is implanted can cause displacement of the catheter tip away from the desired location.

6. Grasp the two handles of the peel-apart sheath and pull outward and upward at the same time.



7. Peel the sheath away from the catheter completely. Make sure the catheter is not dislodged from vessel.

CATHETER TUNNELING PROCEDURE:

1. Create a subcutaneous pocket using blunt dissection. **Note:** Do a trial placement to verify that the pocket is large enough to accommodate the port and that the port does not lie beneath the incision.

Attachable Catheters:

- Create a subcutaneous tunnel from the venous site to the port pocket site using tunneler or long forceps per the following:
 - a. Make a small incision at the venous entry site.
 - b. Insert tip of tunneler into the small incision.
 - c. Form tunnel by advancing tip of tunneler from the venous entry site to the port pocket site. **Caution:** Avoid inadvertent puncture of the skin of fascia with the tip of the tunneler.
 - d. Remove catheter lock from the catheter. **Caution:** Never use a catheter lock that appears cracked or otherwise damaged.
 - e. Attach end of catheter onto the tunneler barb with a twisting motion. **Note:** Barb threads must be completely covered to the extent possible by the catheter as it is pulled through the tunnel. A suture may be tied around the catheter between the tunneler body and the large barb to hold it more securely.
 - f. Pull the tunneler through to the port pocket site while gently holding the catheter. **Note:** The catheter must not be forced.
 - g. Place catheter lock back onto catheter.
 - h. Cut the catheter to the proper length at a 90° angle, allowing sufficient slack for body movement and port connection. Check catheter for any damage. If any damage is noted, cut damaged section off before connecting catheter to port.

CONNECT CATHETER TO PORT:

1. Flush all air from the port body using a 10ml syringe with a non-coring needle filled with heparinized saline (100 USP U/ml). Insert the needle through both septum/reservoirs and inject the fluid while pointing the stem up. Remember that some patients may be hypersensitive to heparin and these patients must not have their port flushed with heparinized saline.
2. Cleanse all system components with irrigation solution.
3. Connect catheter to port:

Caution: Prior to advancing the catheter lock, ensure that the catheter is properly positioned. A catheter not advanced to the proper region may not seat securely and lead to dislodgment and extravasation. The catheter must be straight with no sign of kinking. A slight pull on the catheter is sufficient to straighten it. Advancing the catheter lock over a kinked catheter may damage the catheter. Do not hold the catheter or catheter lock with any instruments that could potentially damage either piece (e.g., hemostats).

 - a. Align port stem with catheter. **Note:** If the catheter and lock are connected and then disconnected, the catheter end must be re-trimmed to ensure a secure re-connection.
 - b. For the Dignity® Dual Port advance the catheter over stem until gap between stem is not visible, while ensuring your grip on catheter does not narrow the lumen. **Note:** Advancing catheter too far along port stem could lead to “mushrooming” of tubing when the catheter lock is advanced. Should this occur, it is advisable to stop advancing the catheter lock, pull the catheter back along the stem away from the port, and re-assemble the connection.
 - c. Advance catheter lock straight until flush with port. Catheter lock should be sufficient to secure catheter to port. Medcomp® does not recommend suturing around the catheter as doing so could compress, kink, or damage catheter.

9.5F Dignity® Dual Port with Polyurethane Catheter

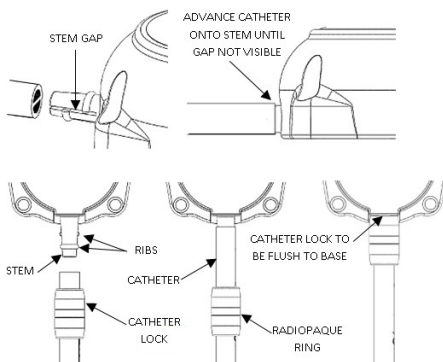

POSITION PORT AND CLOSE INCISION SITE:

1. Place the port in the subcutaneous pocket away from the incision line. This will reduce the risk of port migration and the possibility of it flipping over. Secure the port to the underlying fascia using non-absorbable, monofilament sutures. Leave sufficient slack in the catheter to permit slight movement, and verify that the catheter is not kinked.
2. After suturing the port in the pocket, flush the wound with an appropriate antibiotic solution.
3. Conduct flow studies on the catheter using a non-coring needle and 10ml syringe to confirm flow through both lumens.
4. Confirm aspiration through both lumens.
5. Flush and heparin lock the port system as described under “Heparin Lock Procedure”. Remember that some patients may be hypersensitive to heparin or suffer from heparin induced thrombocytopenia (HIT) and caution should be used when using heparinized saline to lock the port.
6. After therapy completion, flush port per institutional protocol.
7. Close the incision site, so that the port does not lie beneath the incision.
8. Apply dressing according to hospital practice.

HEPARIN LOCK PROCEDURE:

- To help prevent clot formation and catheter blockage, implanted ports with open-ended catheters should be filled with sterile heparinized saline after each use. If the port remains unused for long periods of time, the heparin lock should be changed at least once every four weeks. Remember that some patients may be hypersensitive to heparin and these patients must not have their port locked with heparinized saline.

Determining Port Volumes:

- For Dignity® Dual power injectable implantable infusion port devices, you will need to determine the length of catheter used for each individual patient.
- For system priming volume, multiply the catheter length in cm by 0.017 ml/cm then add the priming volume for the particular port configuration as follows:

Dignity® Dual CT Port, Proximal Reservoir: 0.54 ml
Dignity® Dual CT Port, Distal (furthest from catheter)
Reservoir: 0.64 ml

- For future reference it will be helpful to record this information on the patient's chart and/or patient ID card.

Recommended Flushing Volumes:

FLUSHING VOLUMES *	
PROCEDURES	VOLUME (100 U/ml)
When port not in use	5ml heparinized saline every 4 weeks
After each infusion of medication or TPN	10ml sterile normal saline then 5ml heparinized saline
After blood withdrawal	20ml sterile normal saline then 5ml heparinized saline
After power injection of contrast media	10ml sterile normal saline then 5ml heparinized saline

* For Dignity® Dual Ports flush both reservoirs / lumens

Equipment:

- Non-coring needle
- 10ml syringe filled with sterile saline
- 10ml syringe filled with 5ml heparinized saline (100 U/ml).

Note: Other concentrations of heparinized saline (10 to 1000 U/ml) have been found to be effective. Determination of proper concentration and volume should be based on patient's medical condition, laboratory tests, and prior experience.

Procedure:

1. Explain procedure to patient and prepare injection site.
2. Attach a 10ml syringe filled with sterile normal saline to needle.
3. Aseptically locate and access port.
4. Flush the system, then repeat with 5ml of 100 U/ml heparinized saline. For Dignity® Dual power injectable implantable infusion port flush both reservoirs / lumens.
5. After therapy completion, flush port per institutional protocol. Alcohol should not be used to soak or de clot polyurethane catheters because alcohol is known to degrade the polyurethane catheters over time with repeated and prolonged exposure.

POWER INJECTION PROCEDURE:

Before proceeding follow institutional protocol to verify correct catheter tip position via radiographic image prior to power injection.

Access the port with an appropriate non-coring needle. Make certain that needle tip is inserted fully within the port.

Warning: The Dignity® Dual Port is only power injectable when accessed with a power injectable needle.

6. Attach a syringe filled with sterile normal saline.
7. Instruct the patient to assume the position they will be in during the power injection procedure, before checking for patency. If possible, the patient should receive power injection with his or her arm vertically above the shoulder with the palm of the hand on the face of the gantry during injection. This allows for uninterrupted passage of injected contrast through the axillary and subclavian veins at the thoracic outlet.
8. Aspirate for adequate blood return and vigorously flush the port with at least 10ml of sterile normal saline. For the Dignity® Dual Port aspirate and flush both reservoirs / lumens.

Warning: Failure to ensure patency of the catheter prior to power injection studies may result in port system failure.

9. Detach syringe.
10. Warm contrast media to body temperature.
11. Attach the power injection device to the needle ensuring connection is secure. Check indicated flow rate and confirm CT settings.
12. Instruct the patient to communicate immediately any pain or change in feeling during the injection.

13. Inject warmed contrast, taking care not to exceed the flow rate limits.

Warning: If local pain, swelling or signs of extravasation are noted, the injection should be stopped immediately.

Warning: Exceeding the maximum flow rate may result in port system failure and/or catheter tip displacement.

14. Disconnect the power injection device.

15. Flush the port with 10ml of sterile normal saline. For the Dignity® Dual Port, flush both reservoirs / lumens.

16. Perform heparin lock procedure. Remember that some patients may be hypersensitive to heparin or suffer heparin induced thrombocytopenia (HIT). These patients must not have their port primed with heparinized saline.

17. After therapy completion, flush port per institutional protocol. Close clamp while injecting last 0.5ml of flush solution.

Warning: Do not exceed a 325 psi pressure limit setting, or the maximum flow rate setting shown below, on the power injection machine if power injecting through the Dignity® Dual power injectable implantable infusion port.

Dignity® Dual Port/Catheter Configuration	Average Port Reservoir Pressure ^b	Average Static Burst Pressure ^c	Static Burst Pressure Range ^c
Distal, 9.5F	97 psi	213 psi	205-217 psi
Proximal, 9.5F	81 psi	212 psi	203-220 psi
Indicated CT Flow Rates			
Non-Coring Needle Gauge Size	19 Ga.	20 Ga.	22 Ga.
Maximum Flow Rate ^a	5ml/s	5ml/s	2ml/s
<p>Note: CT injection pressure should be set at a maximum of 325 psi. Flow rates less than 5 ml/s and/or lower viscosity contrast will generate lower pressures in the port and catheter.</p> <p>^a Represents flow capability of port and catheter assembly for power injection of contrast media.</p> <p>^b Internal port pressure during maximum indicated CT flow rate using contrast media with 11.8 Centipoise (cp) viscosity.</p> <p>^c Average static burst pressure and range is the burst pressure of the port catheter assembly.</p>			

Dimension	Needle Penetration Depth	Dignity® Dual Port
A	Distance Thru Septum	6.5mm
B	Distance Thru Septum to Bottom of Proximal Reservoir	11.6mm
C	Distance Thru Septum to Bottom of Distal Reservoir	12.4mm

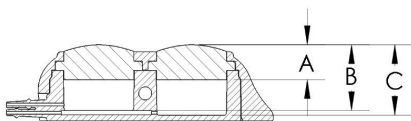

SECTIONED VIEW

MRI Safety Information:

MR Conditional

Non-clinical testing demonstrated that the Dignity® Dual Port, Vascular Access Port is MR Conditional. A patient with this device can be scanned safely in an MR system immediately after placement under the following conditions:

- Static magnetic field of 1.5-Tesla or 3-Tesla
- Maximum spatial field gradient of 4,000-Gauss/cm (40-T/m) or less
- Maximum MR system reported, whole body averaged specific absorption rate (SAR) of 4-W/kg (First Level Controlled Operating Mode).

Under the scan conditions defined above, the Dignity® Dual Port, Vascular Access Port is expected to produce a maximum temperature rise of less than 2.5° C after 15 minutes of continuous scanning”.

In non-clinical testing, the image artifact caused by the Dignity® Dual Port, Vascular Access Port extends approximately 5-mm from the device when imaged using a gradient echo pulse sequence and a 3-Tesla MR system.

Additional Information:

The safety of using the delivery system (i.e. the “kit”) for the Dignity® Dual Port, Vascular Access Port in the MR system room is unknown and these items have not been evaluated for magnetic field interactions, heating, or artifacts. Therefore, these items should not be used in the MR environment.

REFERENCES:

1. Jacobs, D.M. et. al., "Anatomical and Morphological Evaluation of Pacemaker Lead Compression. PACE. 1993 Mar; 16(1):434-444.
2. Magney, J.E. et. al., "Anatomical Mechanisms Explaining Damage to Pacemaker Leads, Defibrillator Leads, and Failure of Central Venous Catheters Adjacent to the Sternoclavicular Joint". PACE. 1993 Mar; 16(1):445-457.
3. Hinke, D.H.; Zandt-Stastny, D.A.; Goodman, L.R.; et. al. "Pinch-off syndrome: A complication of implantable subclavian venous access devices". Radiology 177: 353-356, 1990.
4. Ingle, Rebecca; Nace, Corinne. "Venous Access Devices: Catheter Pinch-off and Fracture." 1993, Bard Access Systems, Inc.
5. Camp-Sorrell, Dawn. "Access Device Guidelines.: 2nd Ed. Oncology Nursing Society, 2004.

FURTHER READING:

- See Medcomp® Implantable Infusion Port Patient Guide and/or CT Guide for more details.
- Contact a Medcomp® Sales Representative for more information about any of these products.

WARRANTY

Medcomp® WARRANTS THAT THIS PRODUCT WAS MANUFACTURED ACCORDING TO APPLICABLE STANDARDS AND SPECIFICATIONS. PATIENT CONDITION, CLINICAL TREATMENT, AND PRODUCT MAINTENANCE MAY AFFECT THE PERFORMANCE OF THIS PRODUCT. USE OF THIS PRODUCT SHOULD BE IN ACCORDANCE WITH THE INSTRUCTIONS PROVIDED AND AS DIRECTED BY THE PRESCRIBING PHYSICIAN.

Because of continuing product improvement, prices, specifications, and model availability are subject to change without notice. Medcomp® reserves the right to modify its products or contents in accordance with all relevant regulatory requirements.

Medcomp® and Dignity® are registered trademarks of Medical Components, Inc.

This device is not made with natural rubber latex.

This device is not made with plasticizer diethylhexylphthalate (DEHP)



Medical Components, Inc.

1499 Delp Drive













Harleysville, PA 19438 U.S.A.

Tel:215-256-4201

Fax:215-256-1787

www.medcompnet.com

SYMBOL TABLE

5.1.1		Manufacturer *
5.3.4		Keep Dry *
5.6.3		Non-pyrogenic *
5.3.2		Keep Away from Sunlight *
5.2.3		Sterilized Using Ethylene Oxide *
5.2.8		Do Not Use if Package is Damaged *
5.1.4		Use-by Date *
5.2.6		Do Not Resterilize *
5.1.5		Batch/Lot Number *
5.1.6		Catalogue Number *
		Prescription Use Only ***
		MR Conditional - 3 Tesla ****

***This symbol is in accordance with ISO 15223-1.**

***** FDA guidance Use of Symbols in Labeling.**

******This Symbol is in accordance with ASTM F 2503-20**